

SUCÇÃO: 2" BSP

RECALQUE: 1 1/2" BSP



Tabela de Códigos e Medidas Bomba Selo

Modelo	CV	Código	A	B	F1	HC	HD
AEX-1 Selo Trif.	1.0	117.01.467041	420	76.2	202	162	-
	1.5	117.01.467051	443			172	
	2.0	117.01.467061	463	172			
	3.0	117.01.467071	483	76.2/127			
AEX-1 Selo Monof.	1.0	117.01.467042	443	76.2	172	210	
	1.5	117.01.467052	463				
	2.0	117.01.467062	473				
	3.0	117.01.467072	493	76.2/127			

Tabela de Códigos e Medidas Bomba Gaxeta

Modelo	CV	Código	A	B	F1	HC	HD
AEX-1 Gaxeta Trif.	1.0	117.01.468041	445	76.2	227	162	-
	1.5	117.01.468051	468			172	
	2.0	117.01.468061	488	172			
	3.0	117.01.468071	508	76.2/127			
AEX-1 Gaxeta Monof.	1.0	117.01.468042	468	76.2	172	210	
	1.5	117.01.468052	488				
	2.0	117.01.468062	498				
	3.0	117.01.468072	518	76.2/127			

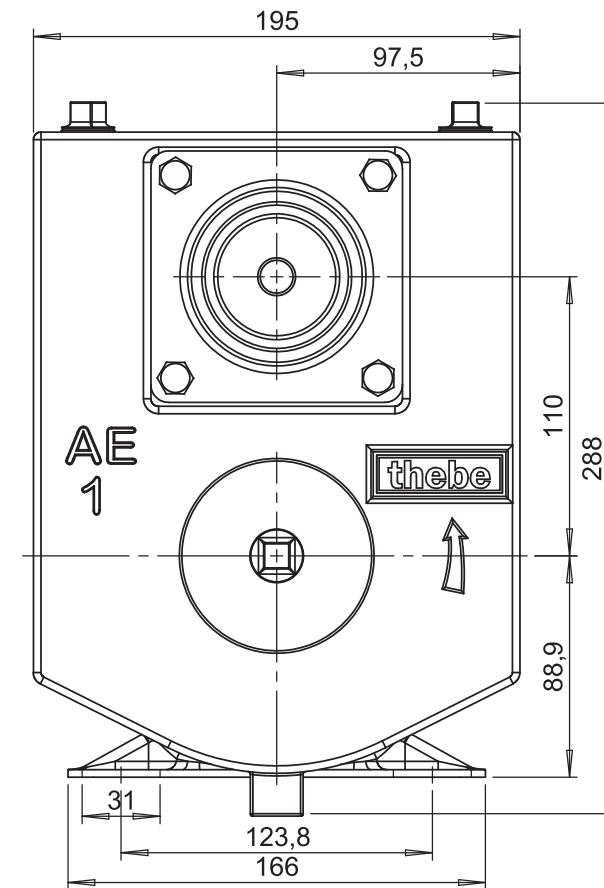
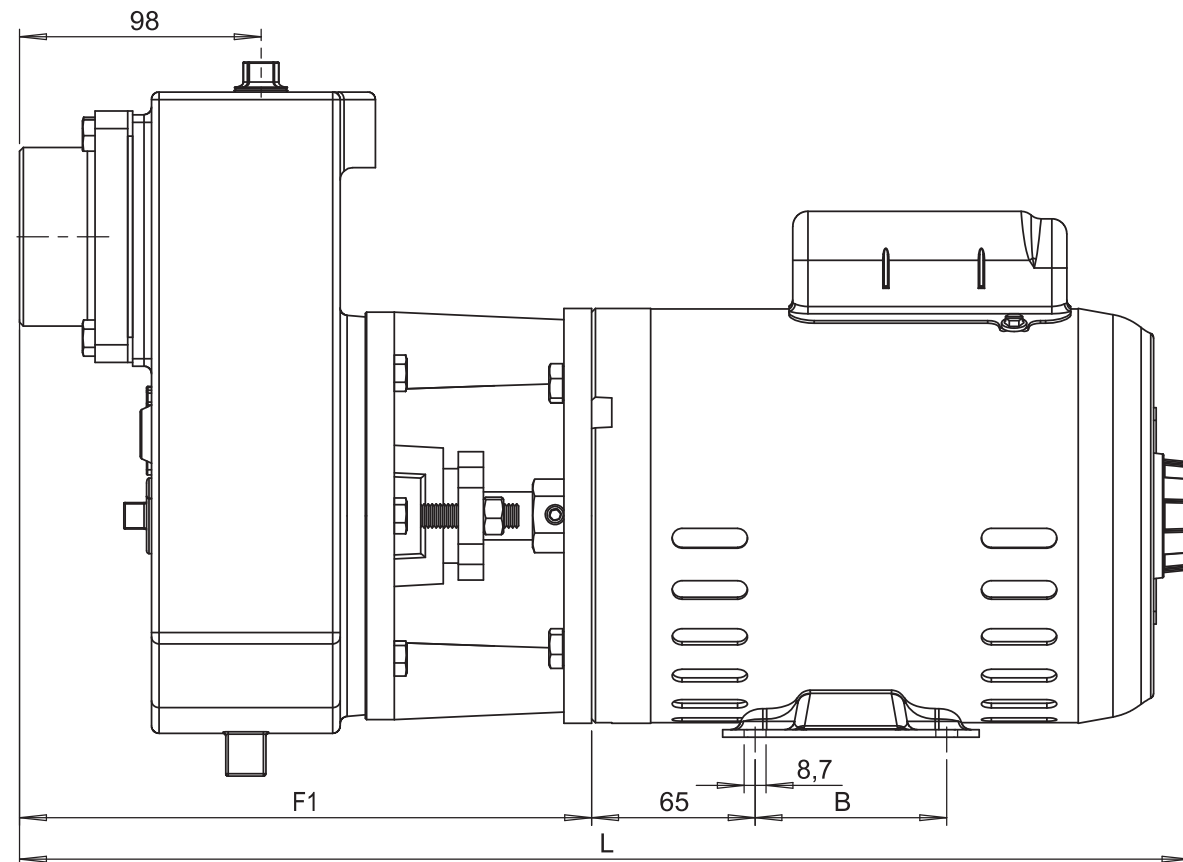

EXECUTADO	NOME	DATA	REVISÃO	LOCAL	DESCRIÇÃO	DATA
LIBERADO	A.P.Scarpel	04/05/09				
	A.P.Scarpel	07/05/09				

AEX-1 Motor Elétrico IP-21

DESENHO Nº
467012



ESCALA: 1:3

MATERIAL :

PESO:

FOLHA 1 de 1

UNID.: Milímetro (mm)

- 264 -